

Gene: *Csf2*

Colony prefix: *MHEM*

ESC clone ID: *DEPD00527_4_D02*

Allele: *Csf2^{tm1(KOMP)Mbp}*

Allele type: *Reporter-tagged deletion allele*

Allele information:

Further information about the allele can be found on the IMPC web site at <http://www.mousephenotype.org/data/alleles/MGI:1339752/tm1%2528KOMP%2529Mbp>? . Details on how to determine the deleted exon can be found at <http://www.i-dcc.org/kb/entry/21/>

Mouse QC information

Promoter Driven:

Promoterless:

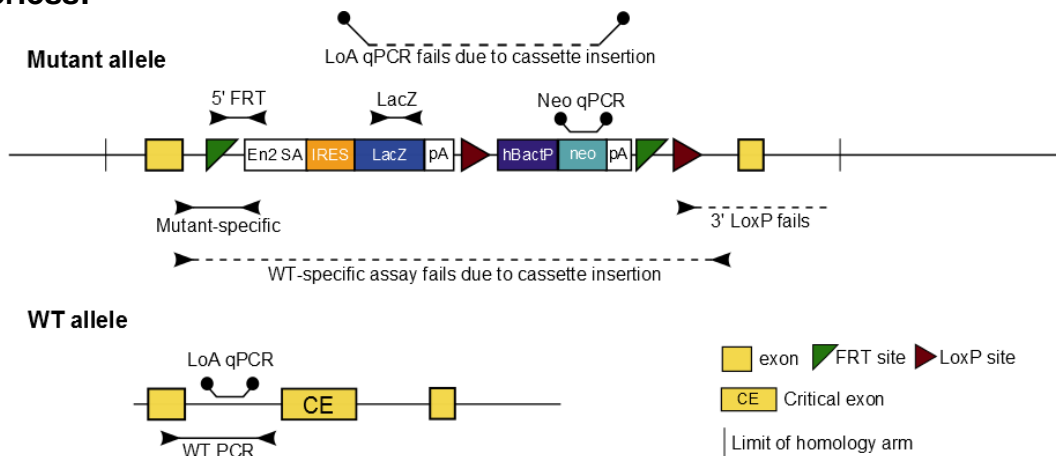

Southern Blot	na	TV Backbone Assay	pass	5' LR-PCR	na
Loss of WT Allele (LOA) qPCR	pass	Homozygous Loss of WT Allele (LOA) SR-PCR	pass	Neo Count (qPCR)	na
LacZ SR-PCR	pass	5' Cassette Integrity	pass	Neo SR-PCR	na
Mutant Specific SR-PCR	pass	LoxP Confirmation	pass	3' LR-PCR	na
Genotyping Comment					

This technical data sheet and information ("Datasheet") is supplied by Genome Research Limited ("GRL").

Although reasonable care is taken in the preparation of this Datasheet, GRL gives no warranties express or implied for any use of the Datasheet or for the accuracy of the Datasheet. GRL assumes no responsibility or liability for any decisions based upon the Datasheet. Without limiting the foregoing the Datasheet was prepared for mice supplied directly from GRL and where copies of this Datasheet are available from third party repositories or distribution centres ("Third Parties") GRL shall not be liable for any inconsistency between the mouse strain supplied by the Third Party and the Datasheet howsoever arising.

Report Generated on: 07-April-2017

Southern blot confirmation:

Southern blots are not routinely performed at the Sanger Institute due to throughput constraints. A southern blot experiment design tool can be found on the IKMC web site at <http://www.knockoutmouse.org/martsearch/project/69506>

Links to information and frequently asked questions about the EUCOMM/KOMP alleles and MGP projects

General targeting strategies:
<http://www.knockoutmouse.org/about/targeting-strategies>

MGP mouse phenotype data:
<http://www.sanger.ac.uk/mouseportal/>

IKMC allele types:
<http://www.knockoutmouse.org/kb/entry/89/>

MGP mouse quality control tests :
<http://www.knockoutmouse.org/kb/25/>

Allele conversion guide - genotyping tm1b, tm1c and tm1d mice:
<http://www.knockoutmouse.org/kb/entry/105/>

How the "critical" exon is decided:
<http://www.knockoutmouse.org/kb/entry/102/>

Genotyping Information

Genotyping by end-point PCR

These mice may be genotyped through a combination of separate PCR reactions that detect the cassette, the gene-specific wild type allele, and a mutant allele-specific short range PCR. Interpretation of the consolidated results produces the genotype of the mice.

For example: cassette positive, mutant positive, wild type positive = heterozygous.

This technical data sheet and information ("Datasheet") is supplied by Genome Research Limited ("GRL").

Although reasonable care is taken in the preparation of this Datasheet, GRL gives no warranties express or implied for any use of the Datasheet or for the accuracy of the Datasheet. GRL assumes no responsibility or liability for any decisions based upon the Datasheet. Without limiting the foregoing the Datasheet was prepared for mice supplied directly from GRL and where copies of this Datasheet are available from third party repositories or distribution centres ("Third Parties") GRL shall not be liable for any inconsistency between the mouse strain supplied by the Third Party and the Datasheet howsoever arising.

Report Generated on: 07-April-2017

PCRs primer pairs and expected size bands

Assay Type	Assay	Forward Primer	Reverse Primer	Expected Size Band (bp)
Standard PCR	Wildtype	Csf2_237288_F	Csf2_237288_R	300
Standard PCR	Mutant	Csf2_237288_F	CAS_R1_Term	204
Standard PCR	Cassette	LacZ_2_small_F	LacZ_2_small_R	108

Primer sequences

Primer Name	Primer Sequence (5' > 3')
CAS_R1_Term	TCGTGGTATCGTTATGCGCC
LacZ_2_small_F	ATCACGACGCGCTGTATC
LacZ_2_small_R	ACATCGGGCAAATAATATCG
Csf2_237288_F	TGGTCTACAGCCTCTCAGCA
Csf2_237288_R	CGGGAAGCTACACCAAAGA

Reaction setup

Reagent	µl
DNA (~50-100 ng)	1
10x Buffer	2
MgCl ₂ (50 mM)	0.6
Platinum Taq (Invitrogen)	0.2
dNTPs (100 mM)	0.2
Primer 1 (10 µM)	0.4
Primer 2 (10 µM)	0.4
ddH ₂ O	15.2
Total	20

Amplification conditions

Step	Conditions	Time
1	94°C	5 min
2	94°C	30 sec
3	58°C	30 sec
4	72°C	45 sec
5	Go to '2' + 34 cycles	-
6	72°C	5 min
7	12°C	forever

This technical data sheet and information ("Datasheet") is supplied by Genome Research Limited ("GRL").

Although reasonable care is taken in the preparation of this Datasheet, GRL gives no warranties express or implied for any use of the Datasheet or for the accuracy of the Datasheet. GRL assumes no responsibility or liability for any decisions based upon the Datasheet. Without limiting the foregoing the Datasheet was prepared for mice supplied directly from GRL and where copies of this Datasheet are available from third party repositories or distribution centres ("Third Parties") GRL shall not be liable for any inconsistency between the mouse strain supplied by the Third Party and the Datasheet howsoever arising.

Report Generated on: 07-April-2017

Relevant publications

- Ryder, E., Gleeson, D., Sethi, D., Vyas, S., Miklejewski, E., Dalvi, P., Habib, B., Cook, R., Hardy, M., Jhaveri, K., et al. (2013). Molecular Characterization of Mutant Mouse Strains Generated from the EUComm/KOMP-CSD ES Cell Resource. *Mamm. Genome*, 24, 286–294.
- Ryder, E., Doe, B., Gleeson, D., Houghton, R., Dalvi, P., Grau, E., ... Ramirez-Solis, R. (2013). Rapid conversion of EUComm/KOMP-CSD alleles in mouse embryos using a cell-permeable Cre recombinase. *Transgenic research*. doi:10.1007/s11248-013-9764-x
- White, J.K., Gerdin, A.-K., Karp, N.A., Ryder, E., Buljan, M., Bussell, J.N., Salisbury, J., Clare, S., Ingham, N.J., Podrini, C., et al. (2013). Genome-wide Generation and Systematic Phenotyping of Knockout Mice Reveals New Roles for Many Genes. *Cell* 154, 452–464.
- Ryder, E., Wong, K., Gleeson, D., Keane, T.M., Sethi, D., Vyas, S., Wardle-Jones, H., Bussell, J.N., Houghton, R., Salisbury, J., et al. (2013). Genomic analysis of a novel spontaneous albino C57BL/6N mouse strain. *Genesis* 51, 523–528.
- Bradley, A., Anastassiadis, K., Ayadi, A., Battey, J.F., Bell, C., Birling, M.-C., Bottomley, J., Brown, S.D., Bürger, A., Bult, C.J., et al. (2012). The mammalian gene function resource: the international knockout mouse consortium. *Mamm Genome* 23, 580–586.
- Birling, M.-C., Dierich, A., Jacquot, S., Héroult, Y., and Pavlovic, G. (2011). Highly-efficient, fluorescent, locus directed Cre and flox deleter mice on a pure C57BL/6N genetic background. *Genesis*.
- Skarnes, W.C., Rosen, B., West, A.P., Koutsourakis, M., Bushell, W., Iyer, V., Mujica, A.O., Thomas, M., Harrow, J., Cox, T., et al. (2011). A conditional knockout resource for the genome-wide study of mouse gene function. *Nature* 474, 337–342.
- Pettitt, S.J., Liang, Q., Rairdan, X.Y., Moran, J.L., Prosser, H.M., Beier, D.R., Lloyd, K.C., Bradley, A., and Skarnes, W.C. (2009). Agouti C57BL/6N embryonic stem cells for mouse genetic resources. *Nat Methods* 6, 493–495.
- Liang, Q., Conte, N., Skarnes, W.C., and Bradley, A. (2008). Extensive genomic copy number variation in embryonic stem cells. *Proc Natl Acad Sci U S A* 105, 17453–17456.
- Farley, F.W., Soriano, P., Steffen, L.S., and Dymecki, S.M. (2000). Widespread recombinase expression using FLPeR (flipper) mice. *Genesis* 28, 106–110.

This technical data sheet and information ("Datasheet") is supplied by Genome Research Limited ("GRL").

Although reasonable care is taken in the preparation of this Datasheet, GRL gives no warranties express or implied for any use of the Datasheet or for the accuracy of the Datasheet. GRL assumes no responsibility or liability for any decisions based upon the Datasheet. Without limiting the foregoing the Datasheet was prepared for mice supplied directly from GRL and where copies of this Datasheet are available from third party repositories or distribution centres ("Third Parties") GRL shall not be liable for any inconsistency between the mouse strain supplied by the Third Party and the Datasheet howsoever arising.

Report Generated on: 07-April-2017