

Gene: Fcgr1

Colony prefix: EULX

ESC clone ID: CEPD0073_1_E03

Allele: *Fcgr1*^{tm1 CreERT2_EGFP)Wtsi}

Allele type: Cre Knock in (Promoter Driven Cassette)

Allele information:

Further information about the allele can be found on the 'Coordination of resources for conditional expression of mutated mouse alleles' (CREATE) web site at <http://www.mousephenotype.org/data/genes/MGI:95498>

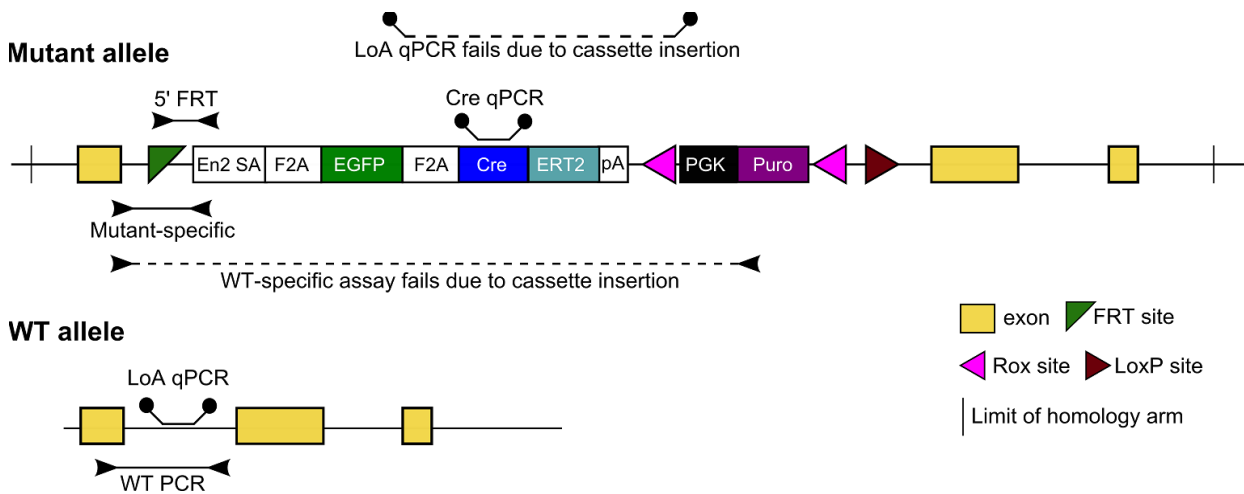

Mouse QC information

Southern Blot	na	TV Backbone Assay	pass	5' LR-PCR	na
Loss of WT Allele (LOA) qPCR	pass	Homozygous Loss of WT Allele (LOA) SR-PCR	na	LoxP Confirmation	na
Mutant Specific SR-PCR	pass	5' Cassette Integrity	pass	3' LR-PCR	na
Genotyping Comment					

This technical data sheet and information ("Datasheet") is supplied by Genome Research Limited ("GRL").

Although reasonable care is taken in the preparation of this Datasheet, GRL gives no warranties express or implied for any use of the Datasheet or for the accuracy of the Datasheet. GRL assumes no responsibility or liability for any decisions based upon the Datasheet. Without limiting the foregoing the Datasheet was prepared for mice supplied directly from GRL and where copies of this Datasheet are available from third party repositories or distribution centres ("Third Parties") GRL shall not be liable for any inconsistency between the mouse strain supplied by the Third Party and the Datasheet howsoever arising.

Report Generated on: 9th December 2016

Southern blot confirmation:

Southern blots are not routinely performed at the Sanger Institute due to throughput constraints. A southern blot experiment design tool can be found on the 'Coordination of resources for conditional expression of mutated mouse alleles' (CREATE) web site at <http://www.creline.org/>

Links to information and frequently asked questions about the EUCOMM/KOMP alleles and MGP projects

General targeting strategies:

http://www.mousephenotype.org/martsearch_ikmc_project/about/targeting-strategies

MGP mouse phenotype data:

<http://www.sanger.ac.uk/mouseportal/>

IKMC allele types:

<http://www.i-dcc.org/kb/entry/89/>

MGP mouse quality control tests :

<http://www.i-dcc.org/kb/25/>

Allele conversion guide - genotyping tm1b, tm1c and tm1d mice:

<http://www.i-dcc.org/kb/entry/105/>

How the "critical" exon is decided:

<http://www.i-dcc.org/kb/entry/102/>

Genotyping Information

Genotyping by end-point PCR

These mice may be genotyped through a combination of separate PCR reactions that detect the cassette, the gene-specific wild type allele, and a mutant allele-specific short range PCR. Interpretation of the consolidated results produces the genotype of the mice.

For example: cassette positive, mutant positive, wild type positive = heterozygous.

This technical data sheet and information ("Datasheet") is supplied by Genome Research Limited ("GRL").

Although reasonable care is taken in the preparation of this Datasheet, GRL gives no warranties express or implied for any use of the Datasheet or for the accuracy of the Datasheet. GRL assumes no responsibility or liability for any decisions based upon the Datasheet. Without limiting the foregoing the Datasheet was prepared for mice supplied directly from GRL and where copies of this Datasheet are available from third party repositories or distribution centres ("Third Parties") GRL shall not be liable for any inconsistency between the mouse strain supplied by the Third Party and the Datasheet howsoever arising.

Report Generated on: 9th December 2016

PCRs primer pairs and expected size bands

Assay Type	Assay	Forward Primer	Reverse Primer	Expected Size Band (bp)
Standard PCR	Wildtype	Fcgr1_211609_F3	Fcgr1_211609_R3	224
Standard PCR	Mutant	Fcgr1_211609_F3	CAS_R1_Term	150
Standard PCR	Cassette	Cre_F	Cre_R	233

Primer sequences

Primer Name	Primer Sequence (5' > 3')
CAS_R1_Term	TCGTGGTATCGTTATGCGCC
Cre_F	CATTGGGCCAGCTAAACAT
Cre_R	TAAGCAATCCCCAGAAATGC
Fcgr1_211609_F3	ACAGTCTGGGTACCGAAAGG
Fcgr1_211609_R3	ACAGCCTTGGTGCCATTAAC

Reaction setup

Reagent	µl
DNA (~50-100 ng)	1
10x Buffer	2
MgCl ₂ (50 mM)	0.6
Platinum Taq (Invitrogen)	0.2
dNTPs (100 mM)	0.2
Primer 1 (10 µM)	0.4
Primer 2 (10 µM)	0.4
ddH ₂ O	15.2
Total	20

Amplification conditions

Step	Conditions	Time
1	94°C	5 min
2	94°C	30 sec
3	58°C	30 sec
4	72°C	45 sec
5	Go to '2' + 34 cycles	-
6	72°C	5 min
7	12°C	forever

This technical data sheet and information ("Datasheet") is supplied by Genome Research Limited ("GRL").

Although reasonable care is taken in the preparation of this Datasheet, GRL gives no warranties express or implied for any use of the Datasheet or for the accuracy of the Datasheet. GRL assumes no responsibility or liability for any decisions based upon the Datasheet. Without limiting the foregoing the Datasheet was prepared for mice supplied directly from GRL and where copies of this Datasheet are available from third party repositories or distribution centres ("Third Parties") GRL shall not be liable for any inconsistency between the mouse strain supplied by the Third Party and the Datasheet howsoever arising.

Report Generated on: 9th December 2016

Genotyping using universal copy number qPCR assays designed to the selection cassette

The cassette qPCR assays use a hydrolysis probe assay (eg Applied Biosystems TaqMan technology) to determine genotype via the copy number of the selection cassette in a sample. Homozygotes will possess two copies, heterozygotes one copy and wild type mice will show no amplification when compared to known homozygote controls.

These FAM®-labeled assays are multiplexed with a VIC® labeled endogenous control assay (for example TaqMan® Copy Number Reference Assay, Mouse, Tfrc; Applied Biosystems part #4458366).

Please note that these assays are not gene-specific – other information should be used in conjunction with the universal cassette assays (for example the mutant-specific srPCR) when confirming the gene identity.

Primer type	Assay Name	Forward Primer Seq.	Reverse Primer Seq.	Probe Primer Seq.
Cassette	Cre_2	ACGTACTGACGGTGGGAGAA	GTGCTAACCAGCGTTTTCGTT	CTGCCAATATGGATTAACA

Reactions are performed in a 10µl volume using an Applied Biosystems 7900HT Fast Real-Time PCR System or Applied Biosystems Viiia7 with DNA prepared using the Sample-to-SNP™ kit (Applied Biosystems) from mouse ear biopsies. GTXpress™ buffer is also used (Applied Biosystems).

Reagent	µl
2x GTXpress™ buffer	5
20x target assay	0.5
ddH2O	3
Tfrc endogenous 20x assay	0.5
DNA	1

Amplification conditions

Step	Conditions	Time
1	95°C	20 sec
2	95°C	10 sec
3	60°C	30 sec
4	Go to '2' + 34 cycles	-

This technical data sheet and information ("Datasheet") is supplied by Genome Research Limited ("GRL").

Although reasonable care is taken in the preparation of this Datasheet, GRL gives no warranties express or implied for any use of the Datasheet or for the accuracy of the Datasheet. GRL assumes no responsibility or liability for any decisions based upon the Datasheet. Without limiting the foregoing the Datasheet was prepared for mice supplied directly from GRL and where copies of this Datasheet are available from third party repositories or distribution centres ("Third Parties") GRL shall not be liable for any inconsistency between the mouse strain supplied by the Third Party and the Datasheet howsoever arising.

Report Generated on: 9th December 2016

Genotyping by loss of WT allele qPCR Assay (gene-specific assay)

The wild type loss of allele (LoA) qPCR assay uses a hydrolysis probe assay (for example Applied Biosystems TaqMan® technology) to determine the copy number of the wild type allele in a sample. Homozygotes will show no amplification, heterozygotes one copy and wild type mice will show two copies when compared to a wild type control.

The number of copies of the wild type allele can be detected using a FAM-labelled custom qPCR TaqMan® assay. These are multiplexed with a VIC® labelled endogenous control assay (for example TaqMan® Copy Number Reference Assay, Mouse, Tfrc; Applied Biosystems part #4458366). Reference DNA controls of known genotypes should also be included to facilitate correct analysis.

Primers for LoA qPCR assay

Primer type	Source	Forward Primer Seq.	Reverse Primer Seq.	Probe Primer Seq.
LoA	Life Technologies	GCCCACTTCTCTTTAAGCATCTGTA	CTGTGGAGAGAACAAAGACCTTGA	ATAACTTGAGCAGAGAAAAGT

Reaction setup

Reaction setup and amplification conditions are the same as those used for the Cre 2 cassette qPCR assay.

This technical data sheet and information ("Datasheet") is supplied by Genome Research Limited ("GRL").

Although reasonable care is taken in the preparation of this Datasheet, GRL gives no warranties express or implied for any use of the Datasheet or for the accuracy of the Datasheet. GRL assumes no responsibility or liability for any decisions based upon the Datasheet. Without limiting the foregoing the Datasheet was prepared for mice supplied directly from GRL and where copies of this Datasheet are available from third party repositories or distribution centres ("Third Parties") GRL shall not be liable for any inconsistency between the mouse strain supplied by the Third Party and the Datasheet howsoever arising.

Report Generated on: 9th December 2016

Relevant publications

Ryder, E., Gleeson, D., Sethi, D., Vyas, S., Miklejewska, E., Dalvi, P., Habib, B., Cook, R., Hardy, M., Jhaveri, K., et al. (2013). Molecular Characterization of Mutant Mouse Strains Generated from the EUCOMM/KOMP-CSD ES Cell Resource. *Mamm. Genome*, 24, 286–294.

Ryder, E., Doe, B., Gleeson, D., Houghton, R., Dalvi, P., Grau, E., ... Ramirez-Solis, R. (2013). Rapid conversion of EUCOMM/KOMP-CSD alleles in mouse embryos using a cell-permeable Cre recombinase. *Transgenic research*. doi:10.1007/s11248-013-9764-x

White, J.K., Gerdin, A.-K., Karp, N.A., Ryder, E., Buljan, M., Bussell, J.N., Salisbury, J., Clare, S., Ingham, N.J., Podrini, C., et al. (2013). Genome-wide Generation and Systematic Phenotyping of Knockout Mice Reveals New Roles for Many Genes. *Cell* 154, 452–464.

Ryder, E., Wong, K., Gleeson, D., Keane, T.M., Sethi, D., Vyas, S., Wardle-Jones, H., Bussell, J.N., Houghton, R., Salisbury, J., et al. (2013). Genomic analysis of a novel spontaneous albino C57BL/6N mouse strain. *Genesis* 51, 523–528.

Bradley, A., Anastassiadis, K., Ayadi, A., Battey, J.F., Bell, C., Birling, M.-C., Bottomley, J., Brown, S.D., Bürger, A., Bult, C.J., et al. (2012). The mammalian gene function resource: the international knockout mouse consortium. *Mamm Genome* 23, 580–586.

Birling, M.-C., Dierich, A., Jacquot, S., Héroult, Y., and Pavlovic, G. (2011). Highly-efficient, fluorescent, locus directed Cre and flpo deleter mice on a pure C57BL/6N genetic background. *Genesis*.

Skarnes, W.C., Rosen, B., West, A.P., Koutsourakis, M., Bushell, W., Iyer, V., Mujica, A.O., Thomas, M., Harrow, J., Cox, T., et al. (2011). A conditional knockout resource for the genome-wide study of mouse gene function. *Nature* 474, 337–342.

Pettitt, S.J., Liang, Q., Rairdan, X.Y., Moran, J.L., Prosser, H.M., Beier, D.R., Lloyd, K.C., Bradley, A., and Skarnes, W.C. (2009). Agouti C57BL/6N embryonic stem cells for mouse genetic resources. *Nat Methods* 6, 493–495.

Liang, Q., Conte, N., Skarnes, W.C., and Bradley, A. (2008). Extensive genomic copy number variation in embryonic stem cells. *Proc Natl Acad Sci U S A* 105, 17453–17456.

Farley, F.W., Soriano, P., Steffen, L.S., and Dymecki, S.M. (2000). Widespread recombinase expression using FLP_{eR} (flipper) mice. *Genesis* 28, 106–110.

This technical data sheet and information ("Datasheet") is supplied by Genome Research Limited ("GRL").

Although reasonable care is taken in the preparation of this Datasheet, GRL gives no warranties express or implied for any use of the Datasheet or for the accuracy of the Datasheet. GRL assumes no responsibility or liability for any decisions based upon the Datasheet. Without limiting the foregoing the Datasheet was prepared for mice supplied directly from GRL and where copies of this Datasheet are available from third party repositories or distribution centres ("Third Parties") GRL shall not be liable for any inconsistency between the mouse strain supplied by the Third Party and the Datasheet howsoever arising.

Report Generated on: 9th December 2016