

**Gene:** Cpgi13101

**Colony prefix:** TABU

**ESC clone ID:** EPD01018\_1\_G12

**Allele:** *Cpgi13101*<sup>tm1(NCC)WCS</sup>

**Allele type:** non-coding RNA, Truncation cassette with conditional potential (selection cassette)

**Allele information:** [http://www.mousephenotype.org/data/alleles/MGI:5678185/tm1\(NCC\)WCS?](http://www.mousephenotype.org/data/alleles/MGI:5678185/tm1(NCC)WCS?)

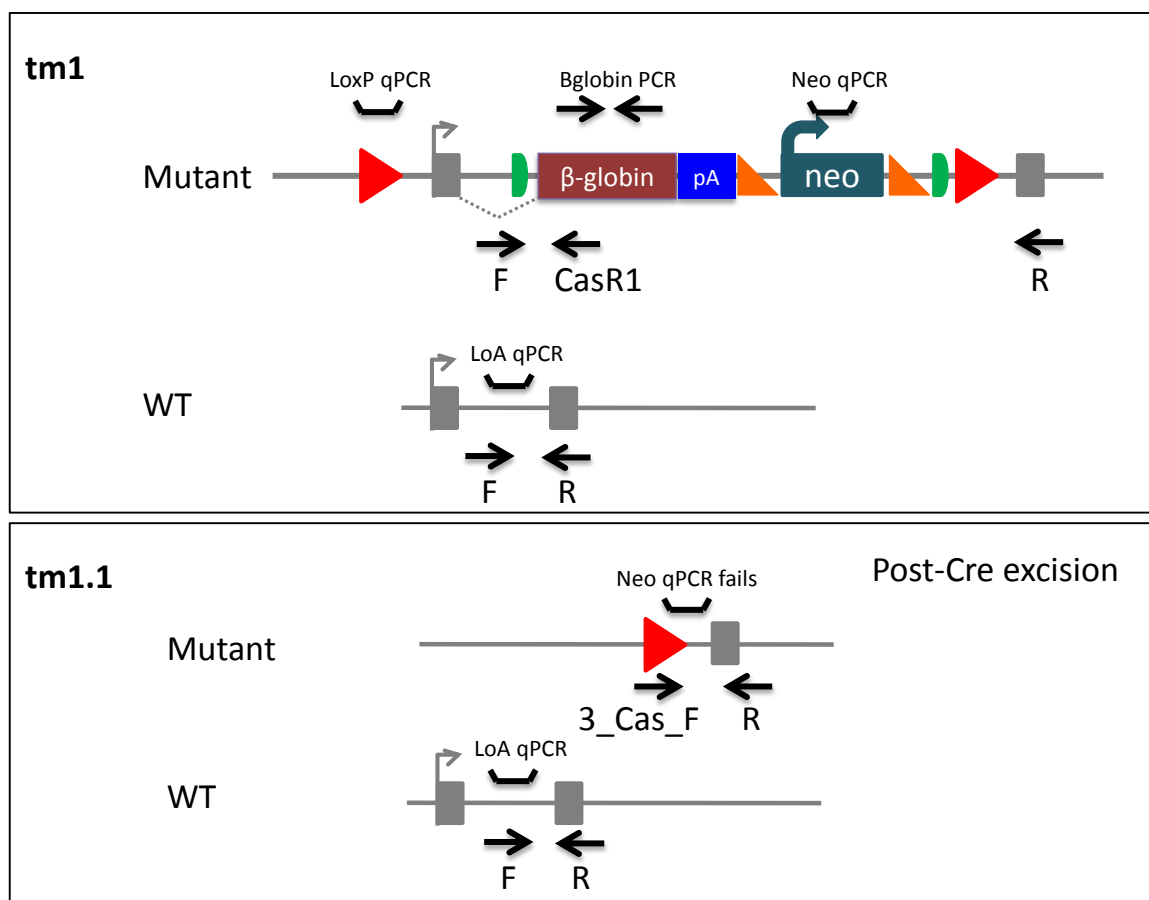

### Mouse QC information

Loss of WT Allele (LOA qPCR)	Pass	Neo qPCR	Pass
Mutant Specific SR-PCR	Pass	LoxP qPCR	Pass
Bglobin cassette SR-PCR	Pass		

This technical data sheet and information ("Datasheet") is supplied by Genome Research Limited ("GRL"). Although reasonable care is taken in the preparation of this Datasheet, GRL gives no warranties express or implied for any use of the Datasheet or for the accuracy of the Datasheet. GRL assumes no responsibility or liability for any decisions based upon the Datasheet. Without limiting the foregoing the Datasheet was prepared for mice supplied directly from GRL and where copies of this Datasheet are available from third party repositories or distribution centres ("Third Parties") GRL shall not be liable for any inconsistency between the mouse strain supplied by the Third Party and the Datasheet howsoever arising.

Report Generated on: 24<sup>th</sup> May 2017

## Genotyping by end-point PCR

### PCRs primer pairs and expected size bands

Assay Type	Assay	Forward Primer	Reverse Primer	Expected Size Band
Standard PCR	Wild type	CGI-13101_F	CGI-13101_R	299
Standard PCR	Mutant	3_Cas_F	CGI-13101_R2	239
Standard PCR	Cassette	R-BGlobin_F	R-BGlobin_R	267

### Primer sequences

Primer Name	Primer Sequence (5' > 3')
3_Cas_F	TCTATAGTCGCAGTAGGCCGG
CGI-13101_F	CTCCCCTCTCCAAAGAATCC
CGI-13101_R	AAACATATAGCTCAGTGCCTTGG
CGI-13101_R2	GCGGTTTAAGAACACCCGTA
R-BGlobin_F	TGTTATATGGAGGGGGCAAA
R-BGlobin_R	ACCCTGATTGCCTTGAAAAA

### Reaction setup

Reagent	µl
DNA (~50-100 ng)	1
10x Buffer	2
MgCl <sub>2</sub> (50 mM)	0.6
Platinum Taq (Invitrogen)	0.2
dNTPs (100 mM)	0.2
Primer 1 (10 µM)	0.4
Primer 2 (10 µM)	0.4
ddH <sub>2</sub> O	15.2
Total	20

### Amplification conditions

Step	Conditions	Time
1	94°C	5 min
2	94°C	30 sec
3	58°C	30 sec
4	72°C	1:30 sec
5	Go to '2' + 34 cycles	-
6	72°C	5 min
7	12°C	forever

This technical data sheet and information ("Datasheet") is supplied by Genome Research Limited ("GRL"). Although reasonable care is taken in the preparation of this Datasheet, GRL gives no warranties express or implied for any use of the Datasheet or for the accuracy of the Datasheet. GRL assumes no responsibility or liability for any decisions based upon the Datasheet. Without limiting the foregoing the Datasheet was prepared for mice supplied directly from GRL and where copies of this Datasheet are available from third party repositories or distribution centres ("Third Parties") GRL shall not be liable for any inconsistency between the mouse strain supplied by the Third Party and the Datasheet howsoever arising.

Report Generated on: 24<sup>th</sup> May 2017

## Genotyping using universal copy number qPCR assays designed to the selection cassette

The cassette qPCR assays use a hydrolysis probe assay (eg Applied Biosystems TaqMan technology) to determine genotype via the copy number of the selection cassette in a sample. Homozygotes will possess two copies, heterozygotes one copy and wild type mice will show no amplification when compared to known homozygote controls.

These FAM®-labeled assays are multiplexed with a VIC® labeled endogenous control assay (for example TaqMan® Copy Number Reference Assay, Mouse, Tfrc; Applied Biosystems part #4458366).

Please note that these assays are not gene-specific – other information should be used in conjunction with the universal cassette assays (for example the mutant-specific srPCR) when confirming the gene identity.

Primer type	Assay Name	Forward Primer Seq.	Reverse Primer Seq.	Probe Primer Seq.
Cassette	Neo	GGTGGAGAGGCTATTCGGC	GAACACGGCGGCATCAG	TGGGCACAACAGACAATCGGCTG

Reactions are performed in a 10µl volume using an Applied Biosystems 7900HT Fast Real-Time PCR System or Applied Biosystems ViiA7 with DNA prepared using the Sample-to-SNP™ kit (Applied Biosystems) from mouse ear biopsies. GTXpress™ buffer is also used (Applied Biosystems).

Reagent	µl
2x GTXpress™ buffer	5
20x target assay	0.5
ddH2O	3
Tfrc endogenous 20x assay	0.5
DNA	1

### Amplification conditions

Step	Conditions	Time
1	95°C	20 sec
2	95°C	10 sec
3	60°C	30 sec
4	Go to '2' + 34 cycles	-

This technical data sheet and information ("Datasheet") is supplied by Genome Research Limited ("GRL"). Although reasonable care is taken in the preparation of this Datasheet, GRL gives no warranties express or implied for any use of the Datasheet or for the accuracy of the Datasheet. GRL assumes no responsibility or liability for any decisions based upon the Datasheet. Without limiting the foregoing the Datasheet was prepared for mice supplied directly from GRL and where copies of this Datasheet are available from third party repositories or distribution centres ("Third Parties") GRL shall not be liable for any inconsistency between the mouse strain supplied by the Third Party and the Datasheet howsoever arising.

Report Generated on: 24<sup>th</sup> May 2017

## Genotyping by loss of WT allele qPCR Assay (gene-specific assay)

The wild type loss of allele (LoA) qPCR assay uses a hydrolysis probe assay (for example Applied Biosystems TaqMan® technology) to determine the copy number of the wild type allele in a sample. Homozygotes will show no amplification, heterozygotes one copy and wild type mice will show two copies when compared to a wild type control.

The number of copies of the wild type allele can be detected using a FAM-labelled custom qPCR TaqMan® assay. These are multiplexed with a VIC® labelled endogenous control assay (for example TaqMan® Copy Number Reference Assay, Mouse, Tfrc; Applied Biosystems part #4458366). Reference DNA controls of known genotypes should also be included to facilitate correct analysis.

### Primers for LoA qPCR assay

Gene	Forward Primer Seq.	Reverse Primer Seq.	Probe Primer Seq.	Source
Cpgi13101	CCCAAATCAACATGAAAACTTACA CCTATTTT	ACGATAGAAATAAGGTAGACTAATT GACAGATGAT	AATGTGTGTCTATCATTATCTG	Life Technologies

Reactions are performed in a 10µl volume using an Applied Biosystems 7900HT Fast Real-Time PCR System or Applied Biosystems Vii7 with DNA prepared using the Sample-to-SNPTM kit (Applied Biosystems) from mouse ear biopsies. GTXpress™ buffer is also used (Applied Biosystems).

Reagent	µl
2x GTXpress™	5
20x target assay	0.5
ddH2O	3
Tfrc endogenous 20x	0.5
DNA	1

### Amplification conditions

Step	Conditions	Time
1	95°C	20 sec
2	95°C	10 sec
3	60°C	30 sec
4	Go to '2' + 34	-

This technical data sheet and information ("Datasheet") is supplied by Genome Research Limited ("GRL").

Although reasonable care is taken in the preparation of this Datasheet, GRL gives no warranties express or implied for any use of the Datasheet or for the accuracy of the Datasheet. GRL assumes no responsibility or liability for any decisions based upon the Datasheet. Without limiting the foregoing the Datasheet was prepared for mice supplied directly from GRL and where copies of this Datasheet are available from third party repositories or distribution centres ("Third Parties") GRL shall not be liable for any inconsistency between the mouse strain supplied by the Third Party and the Datasheet howsoever arising.

Report Generated on: 24<sup>th</sup> May 2017

## Links to information and frequently asked questions

MGP mouse phenotype data:

<http://www.mousephenotype.org>

How the "critical" exon is decided:

<http://www.i-dcc.org/kb/entry/102/>

## Relevant publications

Ryder, E., Gleeson, D., Sethi, D., Vyas, S., Miklejewska, E., Dalvi, P., Habib, B., Cook, R., Hardy, M., Jhaveri, K., et al. (2013). Molecular Characterization of Mutant Mouse Strains Generated from the EUCOMM/KOMP-CSD ES Cell Resource. *Mammalian Genome*. Doi: 10.1007/s00335-013-9467-x

White, J.K., Gerdin, A.-K., Karp, N.A., Ryder, E., Buljan, M., Bussell, J.N., Salisbury, J., Clare, S., Ingham, N.J., Podrini, C., et al. (2013). Genome-wide Generation and Systematic Phenotyping of Knockout Mice Reveals New Roles for Many Genes. *Cell* 154, 452–464.

Ryder, E., Wong, K., Gleeson, D., Keane, T.M., Sethi, D., Vyas, S., Wardle-Jones, H., Bussell, J.N., Houghton, R., Salisbury, J., et al. (2013). Genomic analysis of a novel spontaneous albino C57BL/6N mouse strain. *Genesis* 51, 523–528.

Bradley, A., Anastassiadis, K., Ayadi, A., Battey, J.F., Bell, C., Birling, M.-C., Bottomley, J., Brown, S.D., Bürger, A., Bult, C.J., et al. (2012). The mammalian gene function resource: the international knockout mouse consortium. *Mamm Genome* 23, 580–586.

Birling, M.-C., Dierich, A., Jacquot, S., Héroult, Y., and Pavlovic, G. (2011). Highly-efficient, fluorescent, locus directed Cre and flopo deleter mice on a pure C57BL/6N genetic background. *Genesis*.

Skarnes, W.C., Rosen, B., West, A.P., Koutsourakis, M., Bushell, W., Iyer, V., Mujica, A.O., Thomas, M., Harrow, J., Cox, T., et al. (2011). A conditional knockout resource for the genome-wide study of mouse gene function. *Nature* 474, 337–342.

Pettitt, S.J., Liang, Q., Rairdan, X.Y., Moran, J.L., Prosser, H.M., Beier, D.R., Lloyd, K.C., Bradley, A., and Skarnes, W.C. (2009). Agouti C57BL/6N embryonic stem cells for mouse genetic resources. *Nat Methods* 6, 493–495.

Liang, Q., Conte, N., Skarnes, W.C., and Bradley, A. (2008). Extensive genomic copy number variation in embryonic stem cells. *Proc Natl Acad Sci U S A* 105, 17453–17456.

Farley, F.W., Soriano, P., Steffen, L.S., and Dymecki, S.M. (2000). Widespread recombinase expression using FLP<sub>e</sub>R (flipper) mice. *Genesis* 28, 106–110.

This technical data sheet and information ("Datasheet") is supplied by Genome Research Limited ("GRL").

Although reasonable care is taken in the preparation of this Datasheet, GRL gives no warranties express or implied for any use of the Datasheet or for the accuracy of the Datasheet. GRL assumes no responsibility or liability for any decisions based upon the Datasheet. Without limiting the foregoing the Datasheet was prepared for mice supplied directly from GRL and where copies of this Datasheet are available from third party repositories or distribution centres ("Third Parties") GRL shall not be liable for any inconsistency between the mouse strain supplied by the Third Party and the Datasheet howsoever arising.

Report Generated on: 24<sup>th</sup> May 2017